

PERMA FIREGUARD DOCK SEAL: F-SERIES HEAD CURTAIN

(F: 4" FOAM, EF: 1" FOAM, NF: NO FOAM)

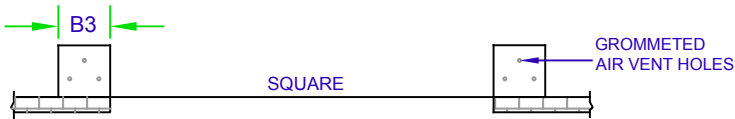

GALVANIZED MOUNTING BRACKETS

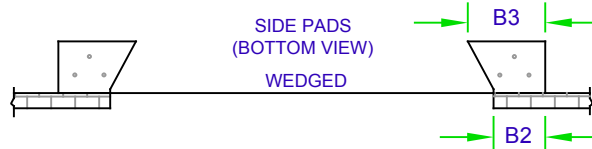
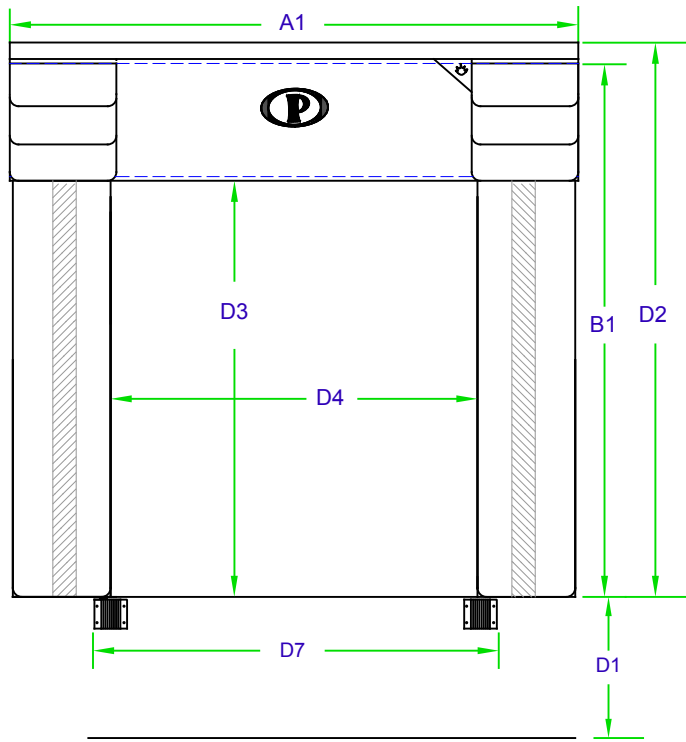
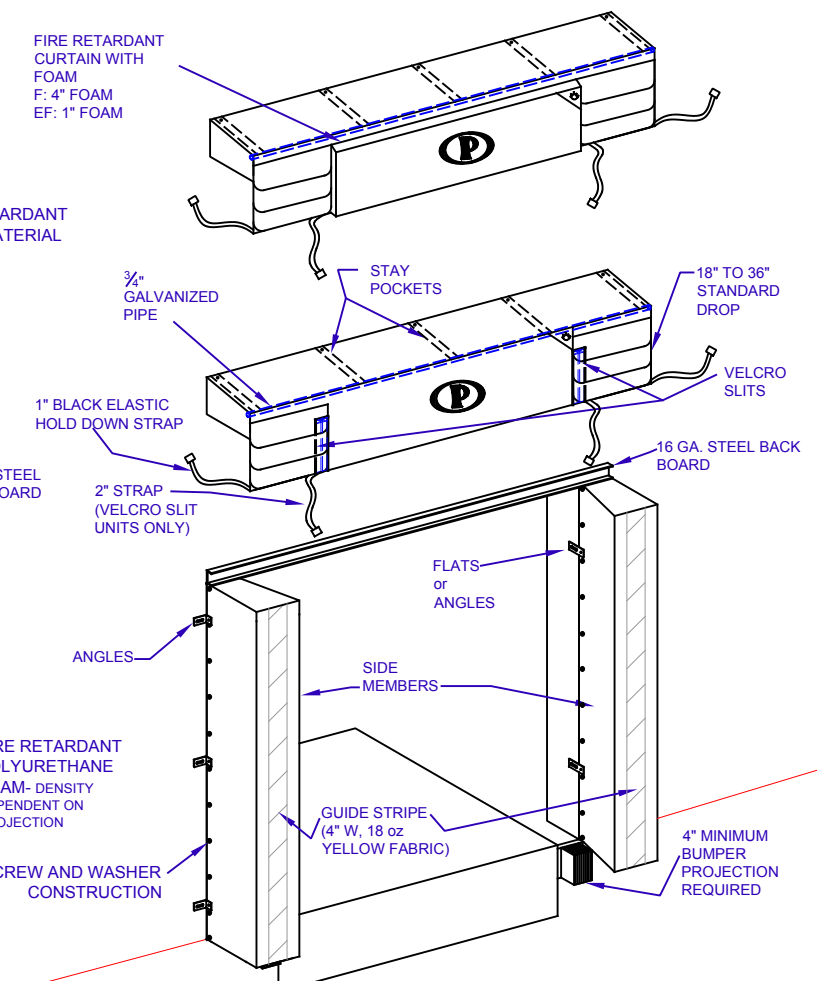
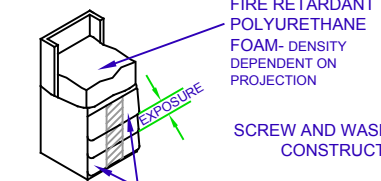
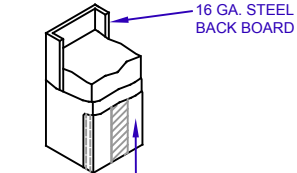
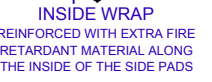
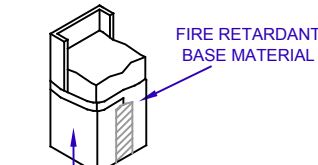
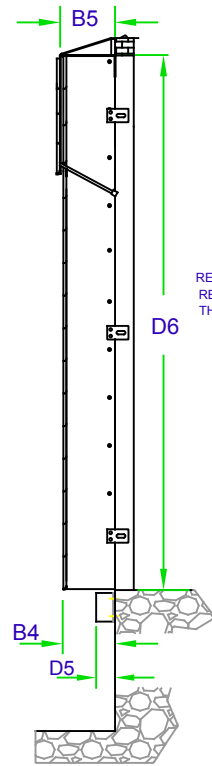
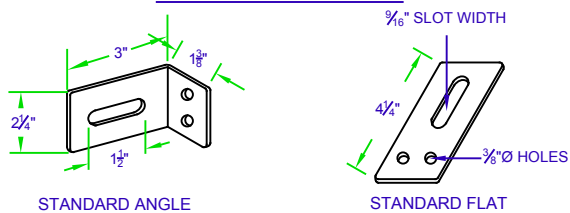

DESIGNED FOR DOORS 9' OR HIGHER

NOTE: LOCATION OF ANGLES & FLATS DETERMINED BY INSTALLER TO SUIT WALL CONFIGURATIONS.

DIMS. HEAD CURTAIN DATA:		GENERAL INFO:	
A1- _____ " LENGTH	MATERIAL- 40 oz FR	APPROACH- DECLINE: <input type="checkbox"/> INCLINE: <input type="checkbox"/> LEVEL: <input type="checkbox"/>	
CURTAIN DROP: _____ "	PERMA PLEATS: <input type="checkbox"/>	D1- _____ " DOCK HEIGHT FROM GROUND	D5- _____ " BUMPER PROJ.
VELCRO SLITS: _____ "	PLEAT MATERIAL- 40 oz FR	D2- _____ " ENTIRE UNIT HEIGHT	D6- _____ " DOOR HEIGHT
	EXPOSURE: _____ "	D3- _____ " INSIDE OPENING HEIGHT	D7- _____ " DOOR WIDTH
3 ROPE PULL-UP: <input type="checkbox"/>	CURTAIN TYPE: F: <input type="checkbox"/> EF: <input type="checkbox"/> NF: <input type="checkbox"/>	D4- _____ " INSIDE OPENING WIDTH	
DIMS. SIDE PAD DATA:		 PERMA TECH, INC. 363 HAMBURG STREET • BUFFALO, NY 14204 (716) 854-0707 • 1-800-DOC-SEAL www.permatechinc.com	
B1- _____ " LENGTH	MATERIAL- 40 oz FR		
B2- _____ " WIDTH AT REAR	WEAR FACE: <input type="checkbox"/>		
B3- _____ " WIDTH AT FACE	INSIDE WRAP: <input type="checkbox"/>		
B4- _____ " PROJ. AT BOTTOM	PERMA PLEATS: <input type="checkbox"/>		
B5- _____ " PROJ. AT TOP	PLEAT MATERIAL- 40 oz FR	JOB:	DATE:
	EXPOSURE- _____ "	DEALER:	CONTACT:
SPECIAL INFORMATION:		APPROVED BY SIGNATURE:	
		QUOTE #:	